

# ELS 500

## Technical data

### FEATURES

- ▶ Easy mounting concept without expensive kits
- ▶ Operating range up to 20 m
- ▶ PNP or NPN output, light or dark switching available
- ▶ Emitting power adjustment

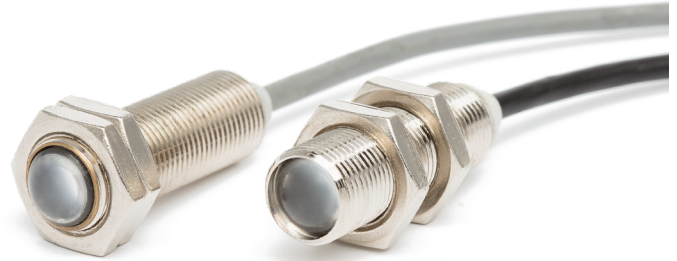

### OPTICAL

Operating range	1 ... 20 m
Aperture angle	
- Emitter	±5° at 12 m
- Receiver	±5° at 12 m

### MECHANICAL

Dimensions	M12 × 42 mm
Housing material	
- Body	M12, stainless steel
- Front	Polycarbonate, black
Enclosure rating	IP67
Temperature range	-25°C ... +60°C

### ELECTRICAL

Supply voltage $U_{Sp}$	10 ... 30 VDC
Current consumption	
- Emitter	< 20 mA at 24 VDC
- Receiver (w/o load)	< 20 mA at 24 VDC
Output	PNP or NPN
Max. output current	100 mA
Response time	< 10 ms

### GENERAL

EMC emission	EN 61000-6-3:2007, EN 12015:2014
EMC immunity	EN 61000-6-2:2019, EN 12016:2013
Vibration	IEC 60068-2-6:2007
Shock	IEC 60068-2-27:2008
RoHS	2011/65/EU
Certificate	CE

### CONNECTION CABLE AND ELECTRICAL CONNECTION

Emitter	
Length connection cable	20 m fix cable
Diameter	Ø 2.9 mm
Material	PVC, gray
Wires	AWG26
• brown	$U_{Sp}$
• blue	GND
• black	Range selector with resistor
Receiver	
Length connection cable	20 m fix cable
Diameter	Ø 2.9 mm
Material	PVC, black
Wires	AWG26
• brown	$U_{Sp}$
• blue	GND
• black	Output



CEDES AG is certified according to ISO 9001: 2015.

**Dimensions**

All dimensions in mm  
Proportions not to scale

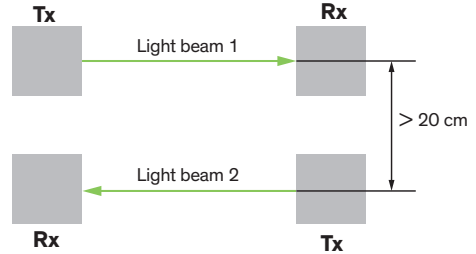
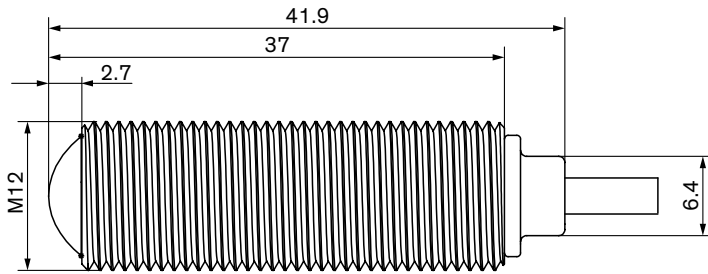

When using two through beam light barriers, pay attention to crossed mounting.

**Output logic**

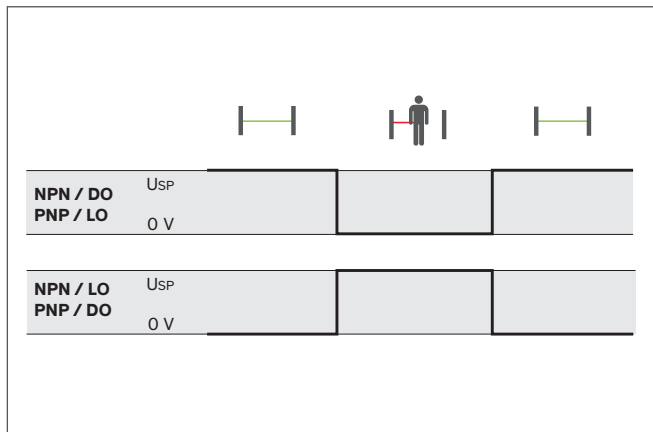

**Electrical connection**

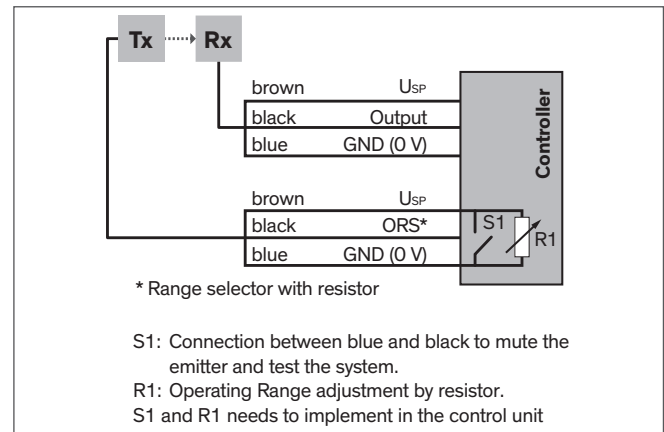

**Application**

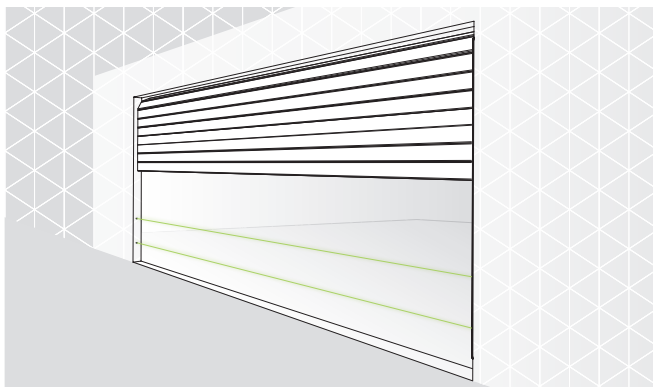

Industrial doors